

DESCRIPTION

- Metal construction with a chrome plated, LifeShine® polished brass, LifeShine® brushed nickel, LifeShine® Satine®, platinum, oil-rubbed bronze or glacier finish
- Pressure balancing cycle valve design with an adjustable temperature limit stop
- 1/2" IPS connections
- Includes adjustable showerhead, arm, flange and diverter tub spout

OPERATION

- Handle operates counterclockwise through a 270° arc with off at 6 o'clock and maximum hot at the 9 o'clock position. Shut off in clockwise direction
- Adjustable temperature limit stop to control maximum hot water temperature
- Pressure balancing mechanism maintains selected discharge temperature to ± 2°

FLOW

- Showerhead is limited to 2.5 gpm (9.5 L/min)

CARTRIDGE

- 1222 cartridge design
- Nonmetallic/nonferrous and stainless steel materials
- Accommodates back to back installations

STANDARDS

- Third party certified to CSA B125, ASME A112.18.1M, ANSI A117.1 and all applicable requirements referenced therein.

WARRANTY

- Lifetime limited warranty against leaks, drips and finish defects to the original consumer purchaser
- 5 year warranty if used in commercial installations



MONTICELLO® POSI-TEMP®
Single-Handle Tub/Shower Valve

Models: 82240PM, 82246, 82248, 82248BN, 82250, 82250PM, 82250ST, 82253ST, 82254, 82301ORB

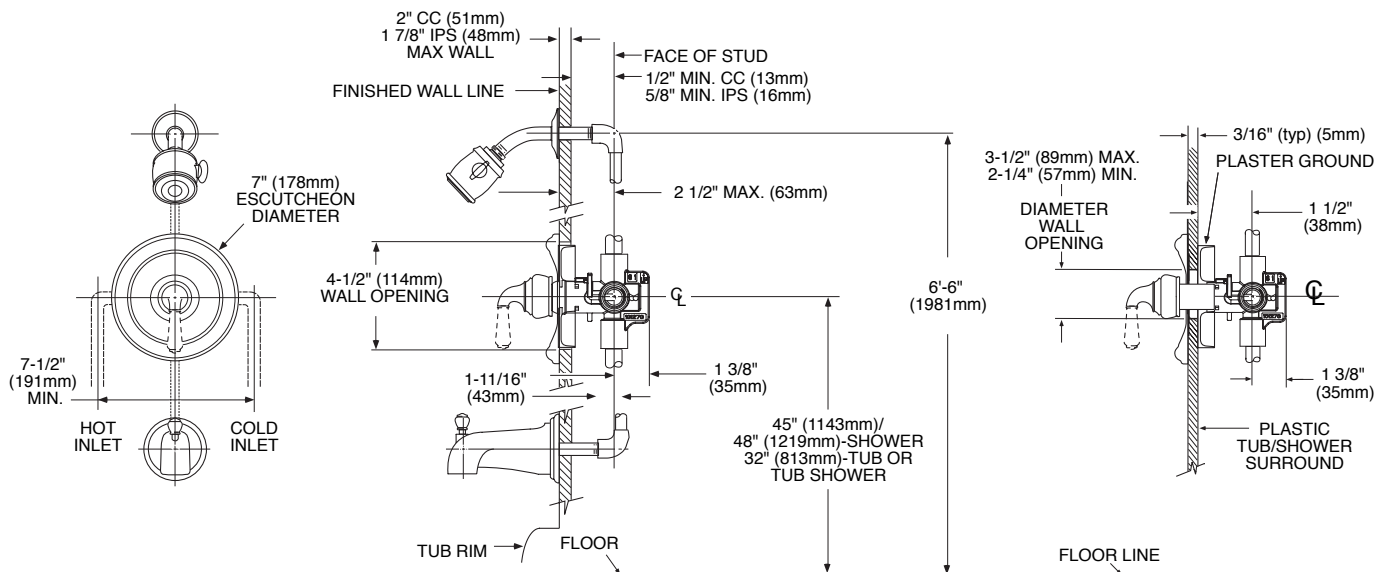

THICK WALL APPLICATION

THIN WALL APPLICATION

CRITICAL DIMENSIONS

(DO NOT SCALE)



ADA symbol applies to shower valve control only.