

DESCRIPTION

- Metal construction with Chrome plating or decorative antique brass, chrome/LifeShine® polished brass, LifeShine® polished brass or glacier finishes
- Fixed mount shower head, arm and flange
- Nonmetallic spray face
- Brass shell and ball assembly

OPERATION

- Adjustable spray - rotate side lever to select coarse to fine spray

FLOW

- Designed to deliver 2.5 gpm (9.5 L/min) max at 60 psi

STANDARDS

- Designed and manufactured to comply with the requirements of: CSA B125 and ASME A112.18.1M and all requirements referenced therein

WARRANTY

- Lifetime limited warranty against leaks, drips and finish defects to the original consumer purchaser
- 5 year warranty if used in commercial installations

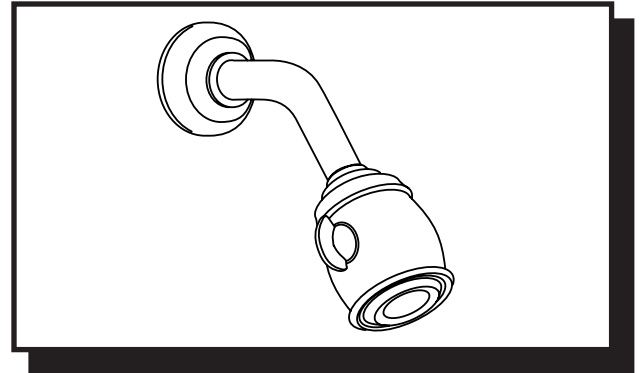

MOENFLO® 40
Head, Arm and Flange

Models: 3941, 3941A, 3941CP, 3941P,
***3941S, 3941W**

*** Discontinued 5/31/02**

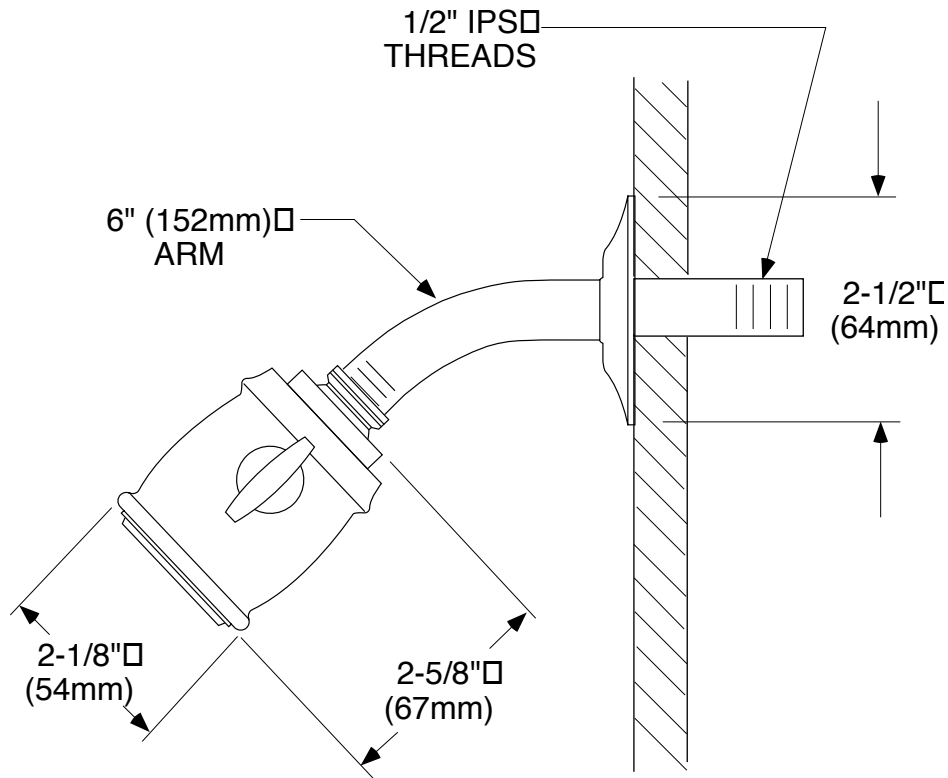

CRITICAL DIMENSIONS

(DO NOT SCALE)