

DESCRIPTION

- Metal construction with a chrome plated or LifeShine® polished brass finish
- 1/2" IPS connections
- Includes adjustable showerhead, arm and flange

OPERATION

- Dual control, Cross style handles with interchangeable inserts
- The valve operates by rotating the "hot" handle counterclockwise to open (clockwise to close) and the "cold" handle rotates clockwise to open (counterclockwise to close)

FLOW

- Showerhead is limited to 2.5 gpm (9.5 L/min)

CARTRIDGE

- 1224 cartridge design
- Nonmetallic and stainless steel materials
- Accommodates either up or down feed installations

STANDARDS

- Third party certified by CSA to meet CSA B-125, ASME A112.18.1M and all applicable requirements referenced therein

WARRANTY

- Lifetime limited warranty against leaks, drips and finish defects to the original consumer purchaser
- 5 year warranty if used in commercial installations

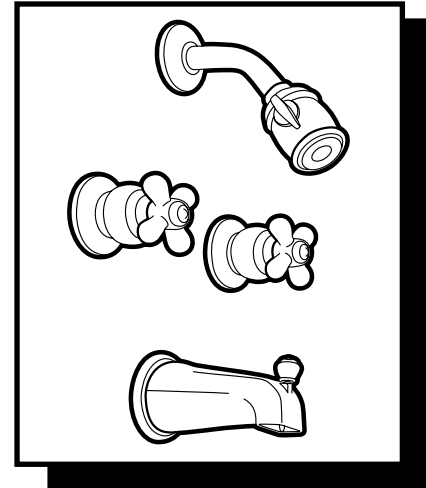

MONTICELLO®
Two-Handle Tub/Shower Valve

Models: 2599, 2599CP, 2599P

NOTE: See reverse side for illustrated parts and optional handle inserts

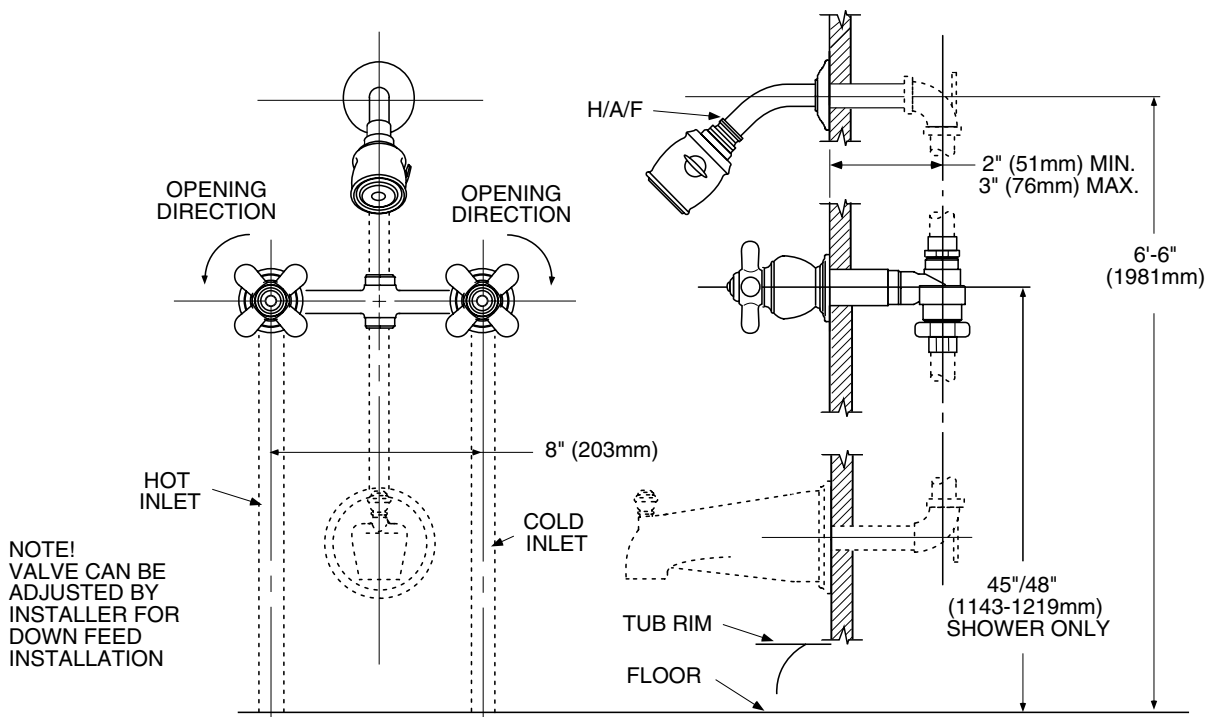

CRITICAL DIMENSIONS

(DO NOT SCALE)